

Specifications of HB series Dynamometers

Model	HB-5MN	HB-10MN	HB-20MN	HB-50MN	HB-100MN	HB-200MN	HB-500MN	HB-1N	HB-2N	HB-5N	HB-10N	HB-20N	HB-50N
Max. Torque	5 mN · m	10 mN · m	20 mN · m	50 mN · m	100 mN · m	200 mN · m	500 mN · m	1 N · m	2 N · m	5 N · m	10 N · m	20 N · m	50 N · m
Torque accuracy	±0.1% of full scale (accuracy of the system including DM5000 Controller, after calibration)												
Max. rotation speed (*1)	40,000 r/min			60,000 r/min			50,000 r/min	30,000 r/min	25,000 r/min	20,000 r/min	12,000 r/min		7,000 r/min
Rotation speed accuracy	±0.01% of reading ±2digit (0.02 r/min)												
Drag torque (at 3,000 r/min)	1 mN · m or less			2 mN · m or less			8 mN · m or less	15 mN · m or less	0.05 N · m or less	0.1 N · m or less	0.25 N · m or less	0.5 N · m or less	1.5 N · m or less
Power rating (5 min)	7.5 W	15 W	30 W	75 W	120 W	170 W	300 W	400 W	600 W	1.5 kW	3 kW	6 kW	12 kW (3 min)
Bearing for brake	Air bearing						Ball bearing						
Moment of inertia of brake rotor	0.6×10^{-6} kg · m ²	0.8×10^{-6} kg · m ²	1.0×10^{-6} kg · m ²	2.6×10^{-6} kg · m ²	3.9×10^{-6} kg · m ²	9.2×10^{-6} kg · m ²	2.8×10^{-5} kg · m ²	1.85×10^{-4} kg · m ²	0.54×10^{-3} kg · m ²	1.8×10^{-3} kg · m ²	6.3×10^{-3} kg · m ²	21×10^{-3} kg · m ²	6.1×10^{-2} kg · m ²
Weight	18 kg			20 kg			26 kg	29 kg	56 kg	63 kg	180 kg	210 kg	500 kg
Standard motor jig	MMJ-7C						MMJ-9C		MMJ-10C		MMJ-12B		(*2)

(*1) All the models have two kinds of low-speed versions, 600P/R type (10-10,000 r/min) and 1200P/R type (5-5,000 r/min).

(*2) Customized fixtures are available for HB-50N, and for all the HB models.

HB-5MN, HB-10MN, HB-20MN

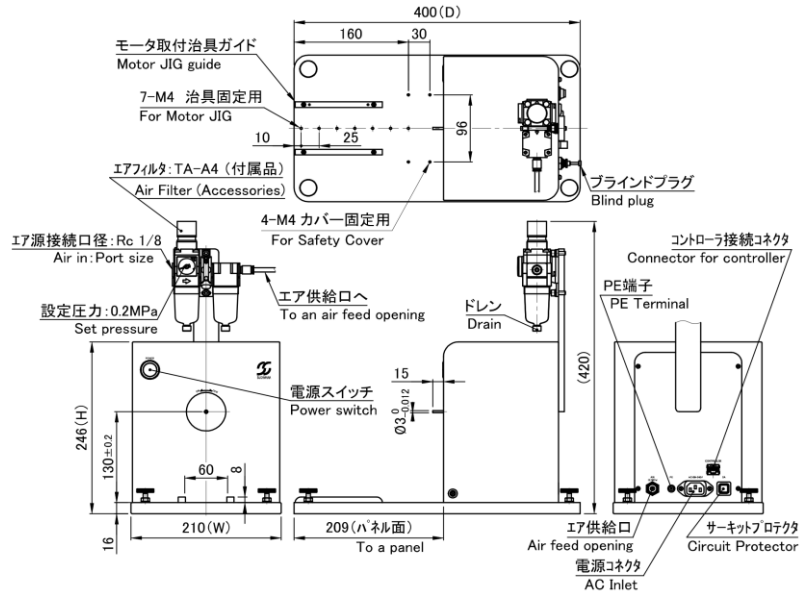

HB-50MN

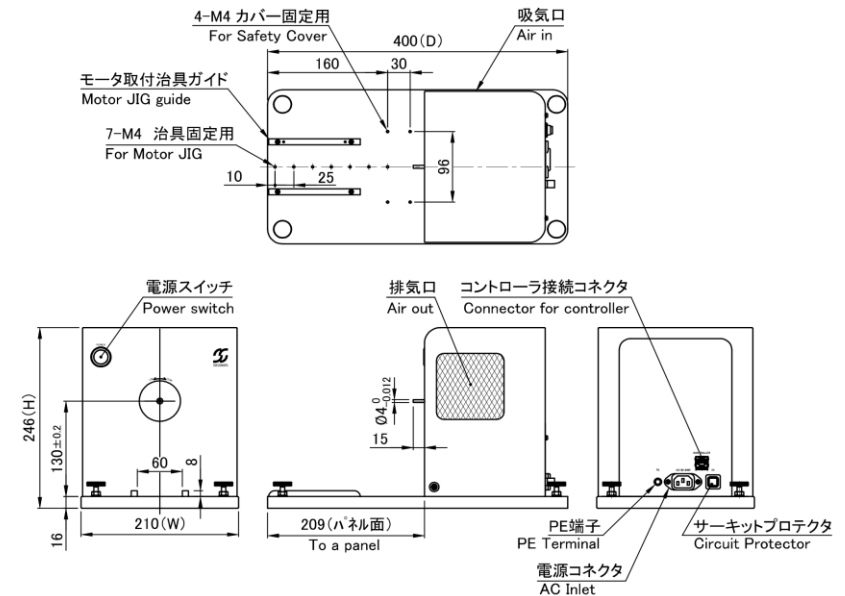

HB-100MN, 200MN

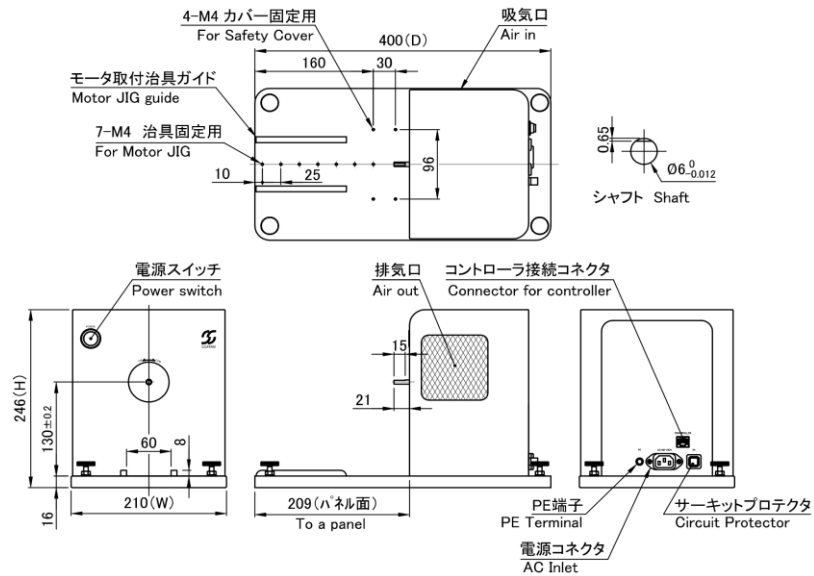

HB-500MN

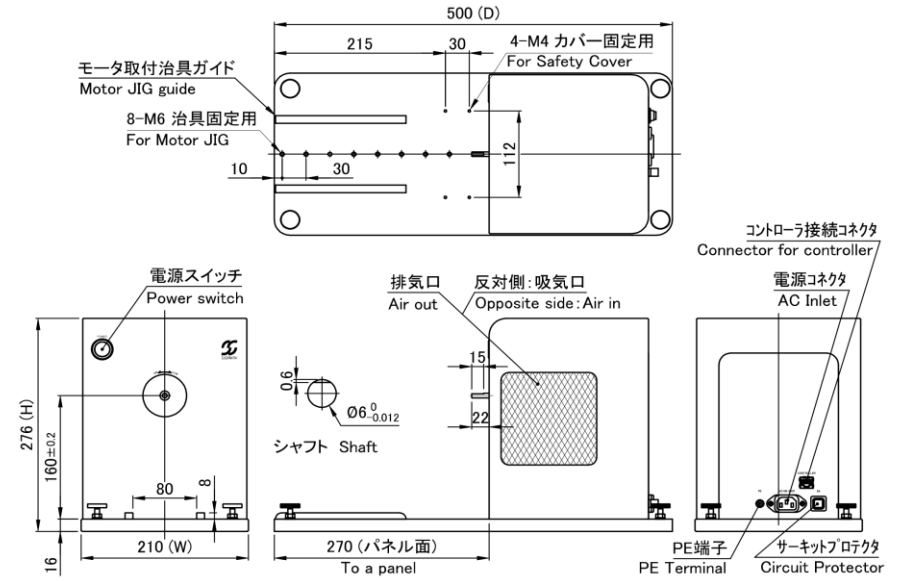

HB-1N

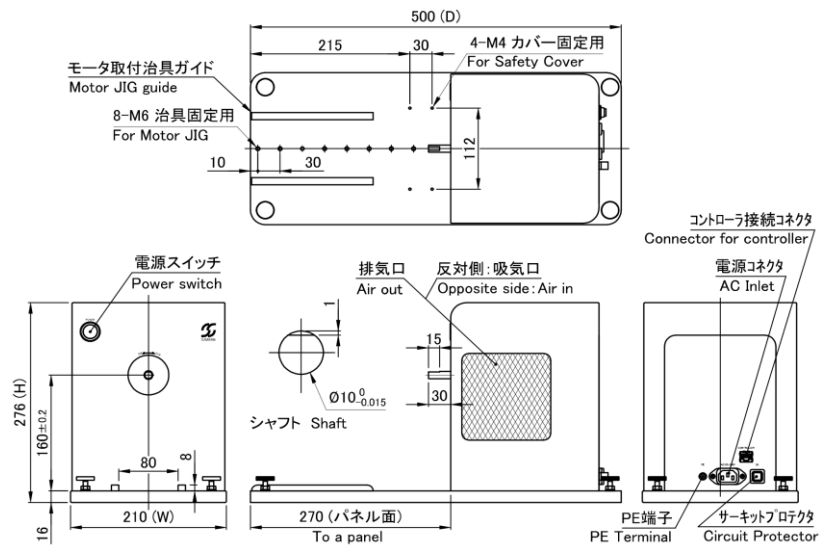

HB-2N

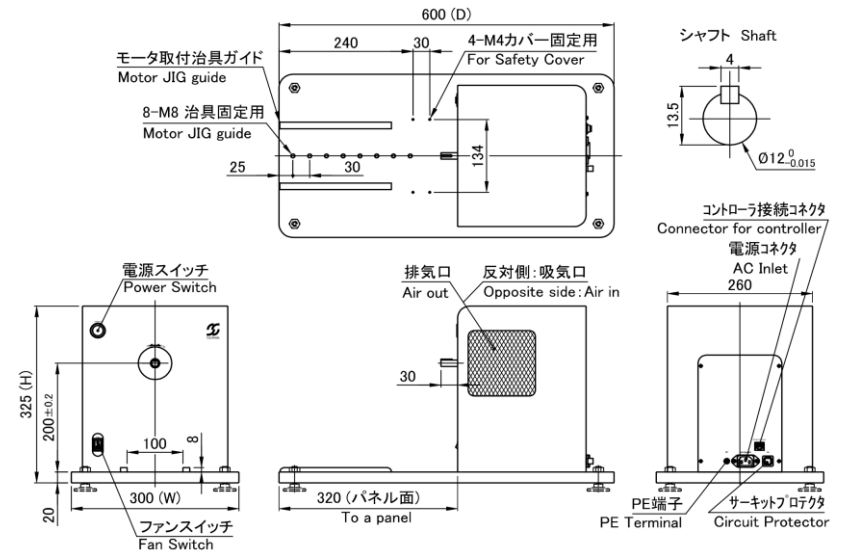

HB-5N

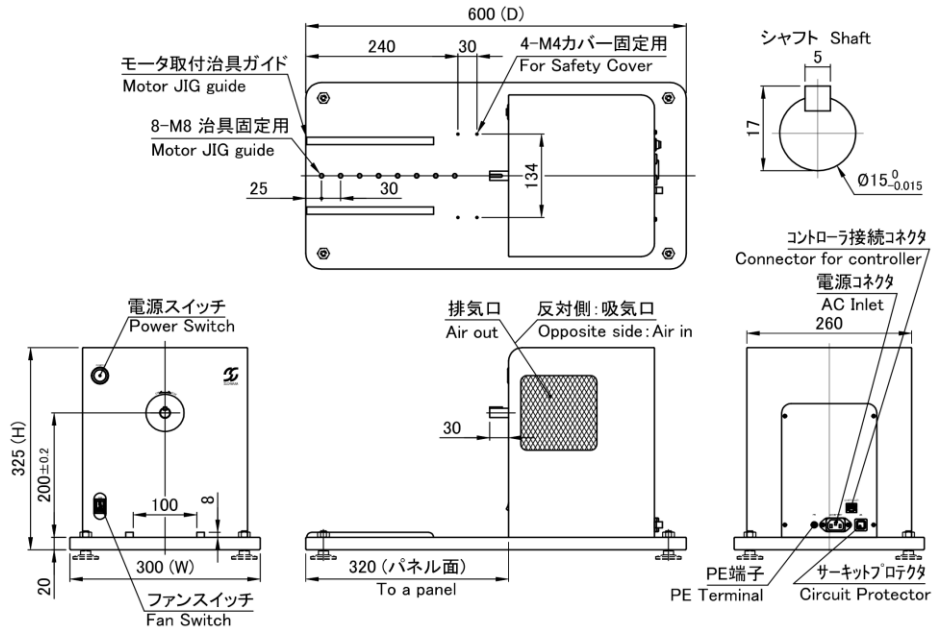

HB-10N

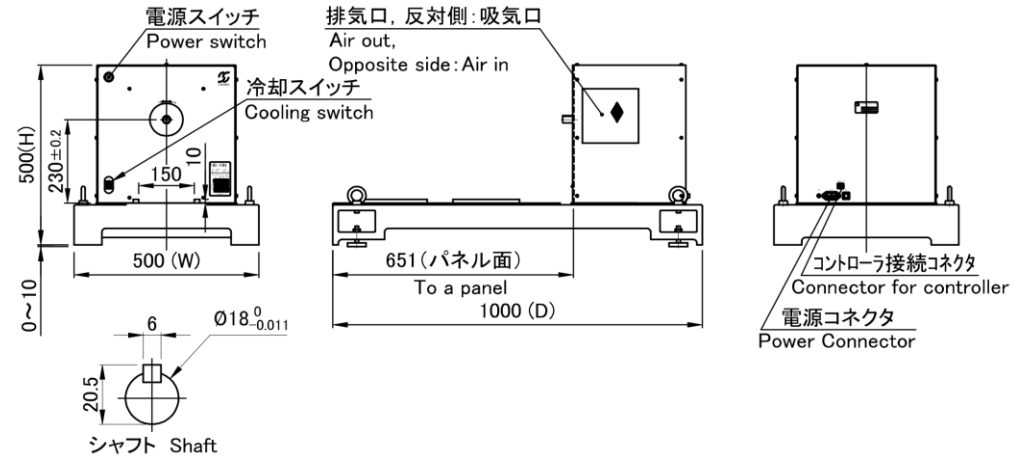

Top view

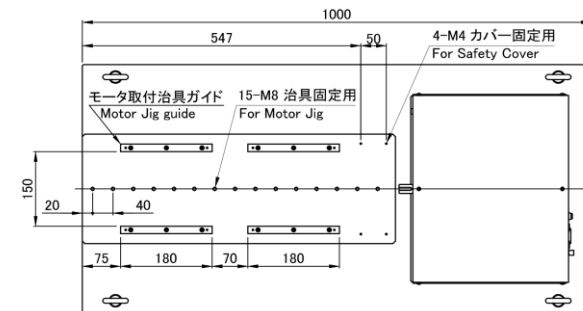

HB-20N

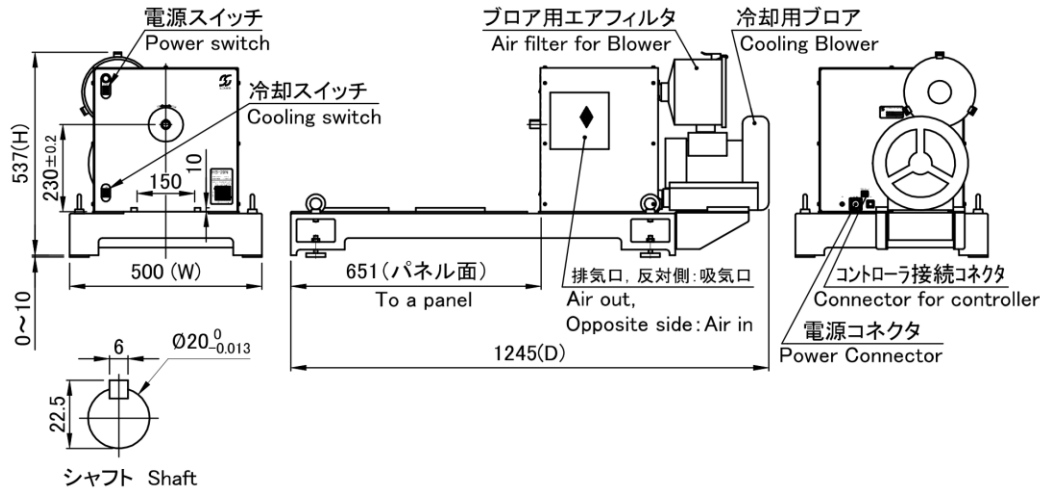

Top view

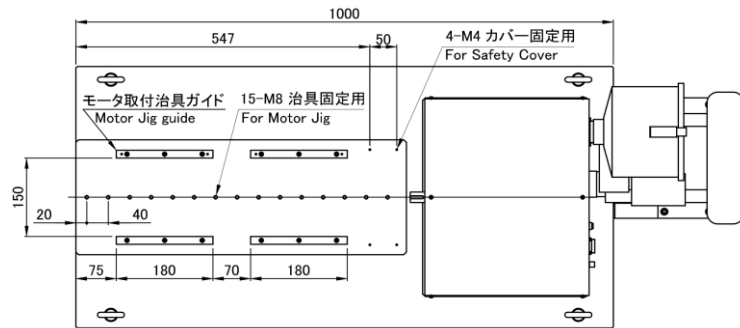

HB-50N

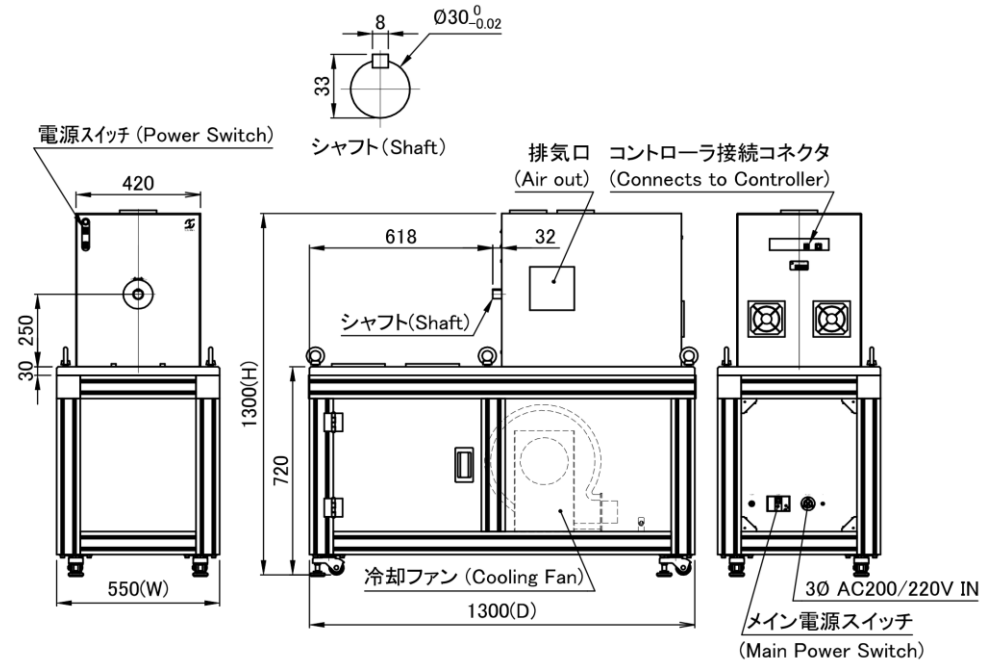

Top view

